

Rotary Screw Compressors BSD Series

With the world-renowned SIGMA PROFILE 

Free air delivery 1.12 to 8.19 m³/min, Pressure 5.5 – 15 bar



BSD Series

BSD – Setting the standard

KAESER KOMPRESSOREN pushes the boundaries of compressed air efficiency once again with its latest generation of BSD series rotary screw compressors. Not only do they deliver more compressed air for less power consumption, but they also combine ease of use and maintenance with exceptional versatility and environmentally responsible design.

BSD – Multiple savings

The new BSD compressors save energy in multiple ways: The compressor airends are equipped with flow-optimised SIGMA PROFILE rotors and are controlled and monitored via the industrial PC-based SIGMA CONTROL 2 compressor controller. This enables free air delivery to be precisely matched to meet actual compressed air demand and ensures maximum energy efficiency. Last, but not least, the use of **Super Premium Efficiency IE4** motors boosts energy efficiency even further.

Ease of maintenance ensures savings

The distinctive and eye-catching design of these systems from the outside is complemented by intelligent component layout on the inside for even greater energy efficiency: All service and maintenance points are within easy reach and directly accessible. This saves both time and money when it comes to servicing.

Perfect partners

BSD series rotary screw compressors are perfect partners for high efficiency industrial compressed air systems. The internal SIGMA CONTROL 2 compressor controller offers multiple communication channels, which allows seamless communication with advanced master controllers, such as KAESER's SIGMA AIR MANAGER, and in-house centralised control systems. This enables simple setup and achieves unprecedented levels of efficiency.

Electronic Thermo Management (ETM)

Powered via an electric motor, the sensor-controlled temperature control valve integrated into the cooling circuit is the heart of the innovative Electronic Thermo Management (ETM) system. The new SIGMA CONTROL 2 compressor controller monitors intake and compressor temperature in order to prevent condensate formation, even with differing air humidity conditions. ETM dynamically controls the fluid temperature – low fluid temperature increases energy efficiency. This system also enables the end user to better adapt heat recovery systems to suit his or her specific needs.

Potential energy cost savings through heat recovery

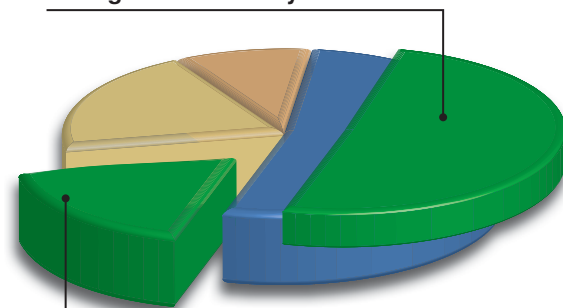

Energy cost savings through system optimisation

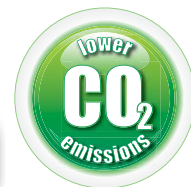

- Compressed air system investment
- Maintenance costs
- Energy costs
- Potential energy cost savings

Service-friendly design



Image: BSD 83



BSD series

Uncompromising efficiency



SIGMA PROFILE air end

At the heart of every BSD system lies a premium quality air end featuring Kaeser's SIGMA PROFILE rotors. Operating at low speed, KAESER's air ends are equipped with flow-optimised rotors for superior efficiency.



The future, today: IE4 motors

KAESER is currently the only compressed air systems provider to equip its compressors with Super Premium Efficiency IE4 motors as standard, thereby ensuring maximum performance and energy efficiency.



SIGMA CONTROL 2

The SIGMA CONTROL 2 ensures efficient control and system monitoring. The large display and RFID reader provide effective communication and maximum security. Multiple interfaces offer exceptional flexibility, whilst the SD card slot makes updates quick and easy.



Electronic Thermo Management

The innovative Electronic Thermo Management (ETM) system dynamically controls fluid temperature to provide reliable prevention of condensate accumulation. This enhances energy efficiency, for example, by enabling heat recovery to be precisely tailored to meet customers' exact needs.

BSD T series

Premium compressed air quality with an integrated refrigeration dryer

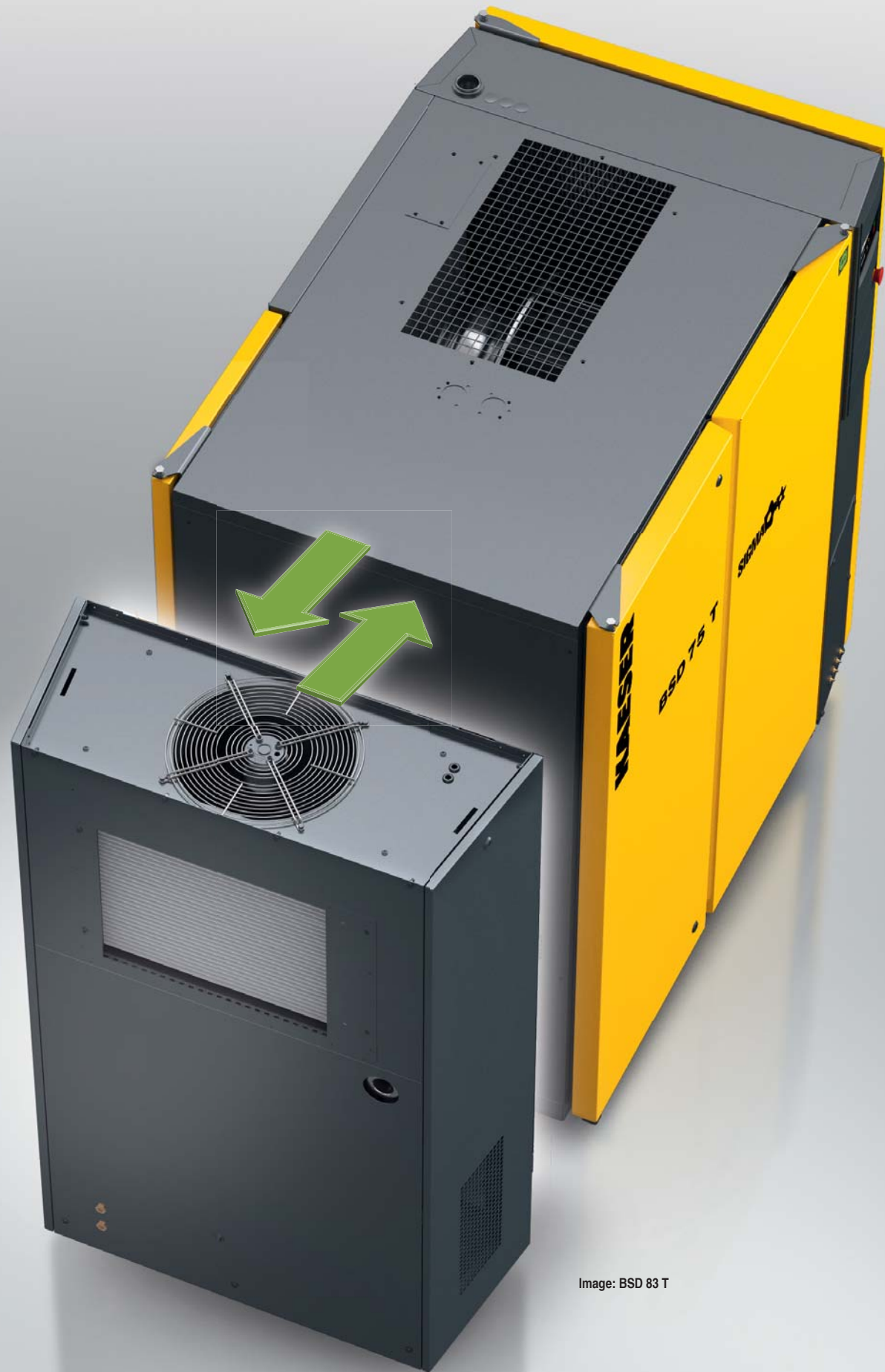
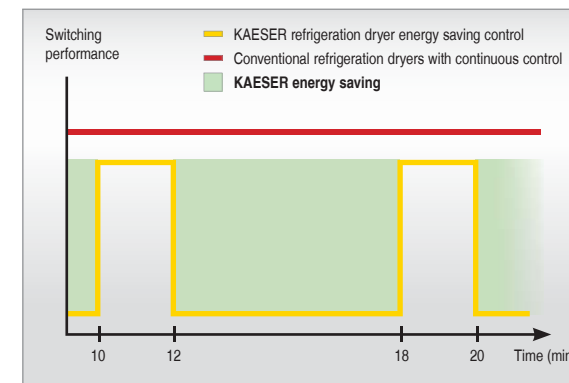

Image: BSD 83 T



Energy-saving control

The integrated refrigeration dryer in BSD-T units provides high efficiency performance thanks to its energy-saving control. The dryer is active only when compressed air actually needs to be dried: This approach therefore achieves the required compressed air quality with maximum efficiency.



Refrigeration dryer with ECO-DRAIN

The refrigeration dryer also features an ECO-DRAIN. The advanced level-controlled condensate drain eliminates the compressed air losses associated with solenoid valve control. This both saves energy and considerably enhances the reliability of the compressed air supply.



Dependable centrifugal separator

A KAESER axial centrifugal separator fitted with an electronic ECO-DRAIN condensate drain installed upstream from of the refrigeration dryer ensures that condensate is reliably pre-separated and drained, even when ambient temperatures and humidity are high.

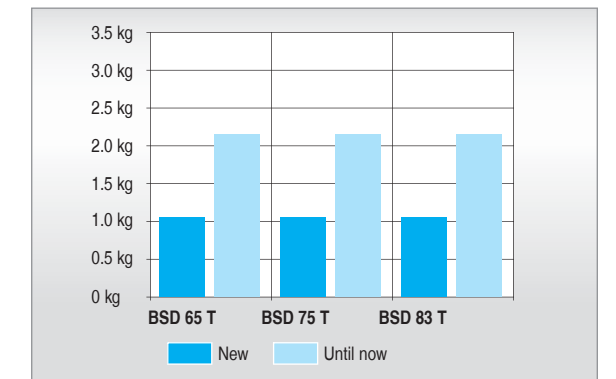

Minimal refrigerant required

The refrigeration dryers in KAESER's new BSD-T units require approximately fifty percent less refrigerant than conventional dryers. This not only saves costs, but is also significantly more environmentally compatible.

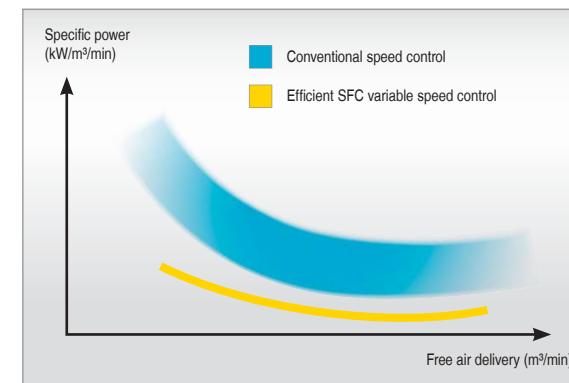

Image: BSD 75 T SFC

Externally lubricated drive motor and fan motor

BSD SFC series

Variable speed control perfected



Optimised specific power

The variable speed compressor is the most heavily loaded piece of equipment in every compressor station. With its wide control range, the BSD-SFC model is therefore designed with optimum efficiency in mind. This saves energy, maximises service life and enhances reliability.

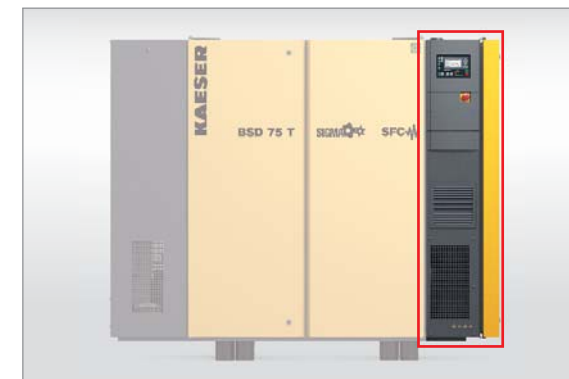

Separate SFC control cabinet

The SFC variable speed drive is housed in its own control cabinet to shield it from heat from the compressor. A separate fan keeps operating temperatures in the optimum range to ensure maximum performance and service life.

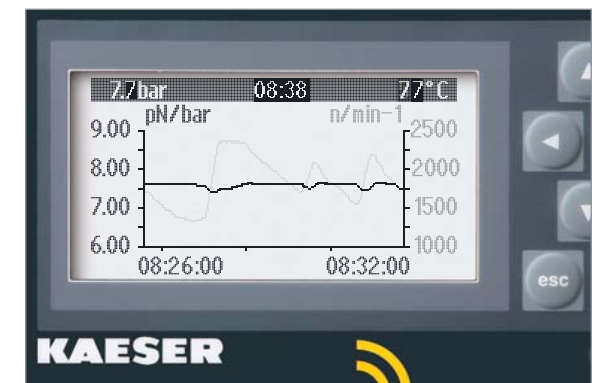

Precision pressure control

The volumetric flow rate can be adjusted within the control range according to pressure. As a result, operating pressure is precisely maintained to within ± 0.1 bar. This allows maximum pressure to be reduced which saves both energy and money.



EMC certified

It goes without saying that the SFC control cabinet and SIGMA CONTROL 2 are tested and certified both as individual components and as a system to EMC directive EN 55011 for Class A1 industrial power supplies.



Equipment

Complete unit

Ready-to-run, fully automatic, super-silenced, vibration damped, all panels powder coated. Suitable for use in ambient temperatures up to +45°C.

Sound insulation

Panels lined with laminated mineral wool.

Vibration damping

Double insulated anti-vibration mountings using rubber bonded metal elements.

Airend

Genuine KAESER rotary screw, single stage airend with energy-saving SIGMA PROFILE and cooling fluid injection for optimised rotor cooling. 1:1 direct drive.

Drive

Direct, high-flex coupling, without gearing.

Electric motor

Super-Premium-Efficiency IE4 motor, quality German manufacture, IP 55, ISO F for additional reserve; PT 100 winding temperature sensor for motor monitoring; externally lubricated bearings.

Electrical components

IP 54 control cabinet, control transformer, Siemens frequency converter, floating contacts for ventilation control.

Fluid and air flow

Dry air filter; pneumatic inlet and venting valve; cooling fluid reservoir with triple separation system; pressure relief valve, minimum pressure check valve, thermostatic valve and micro-filter in coolant circuit, all fully piped using flexible couplings.



Rotary screw airend with energy-saving SIGMA PROFILE rotors

Cooling

Air-cooled; separate aluminium cooler for compressed air and cooling fluid; radial fan with separate electric motor, externally lubricated bearings, Electronic Thermo Management (ETM). Water-cooled option: with plate-type or shell and tube heat exchangers.

Refrigeration dryer

CFC-free, R134a refrigerant, fully insulated, hermetically sealed refrigerant circuit, scroll refrigerant compressor with energy-saving shut-off feature, hot-gas bypass control, electronic condensate drain and upstream centrifugal separator.

Heat recovery (HR)

Optionally available with integrated HR system (plate-type heat exchanger).

SIGMA CONTROL 2

“Traffic light” LED indicators show operational status at a glance, plain text display, 30 selectable languages, soft-touch keys with icons, fully automated monitoring and control. Selection of Dual, Quadro, Vario, Dynamic and continuous control as standard. Interfaces: Ethernet; additional optional communication modules for: Profibus DP, Modbus, Profinet and Devicenet; SD card slot for data recording and updates; RFID reader, web server.

General design

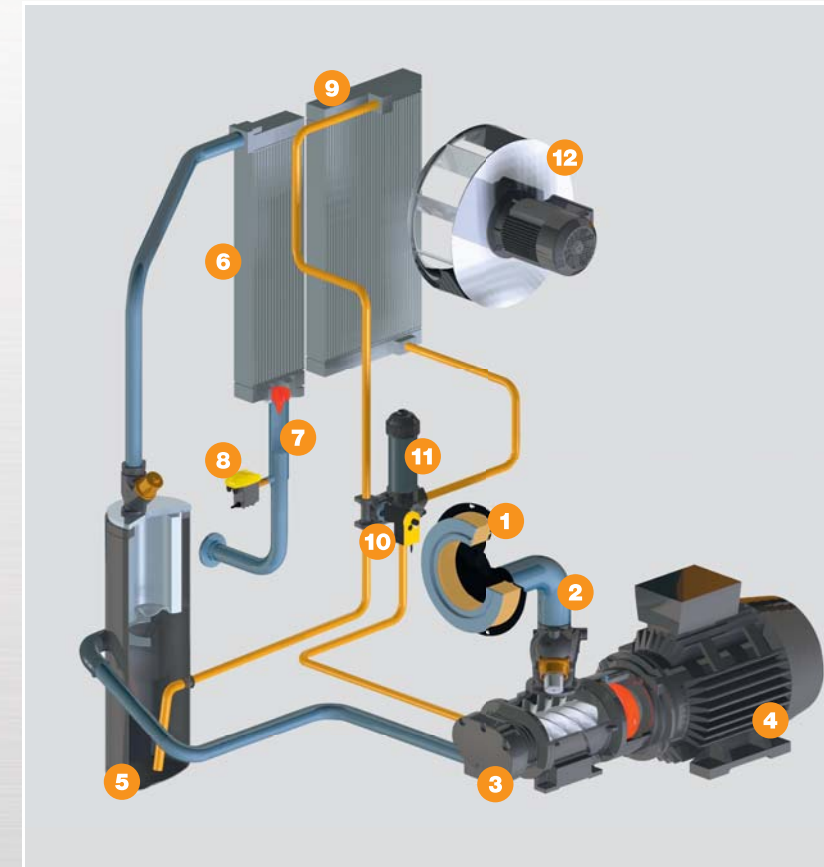

Standard version

- 1 Intake filter
- 2 Inlet valve
- 3 Airend
- 4 Drive motor
- 5 Fluid separator tank
- 6 Compressed air aftercooler
- 7 KAESER centrifugal separator
- 8 Condensate drain (ECO-DRAIN)
- 9 Fluid cooler
- 10 Electrical temperature valve
- 11 Fluid filter
- 12 Radial fan

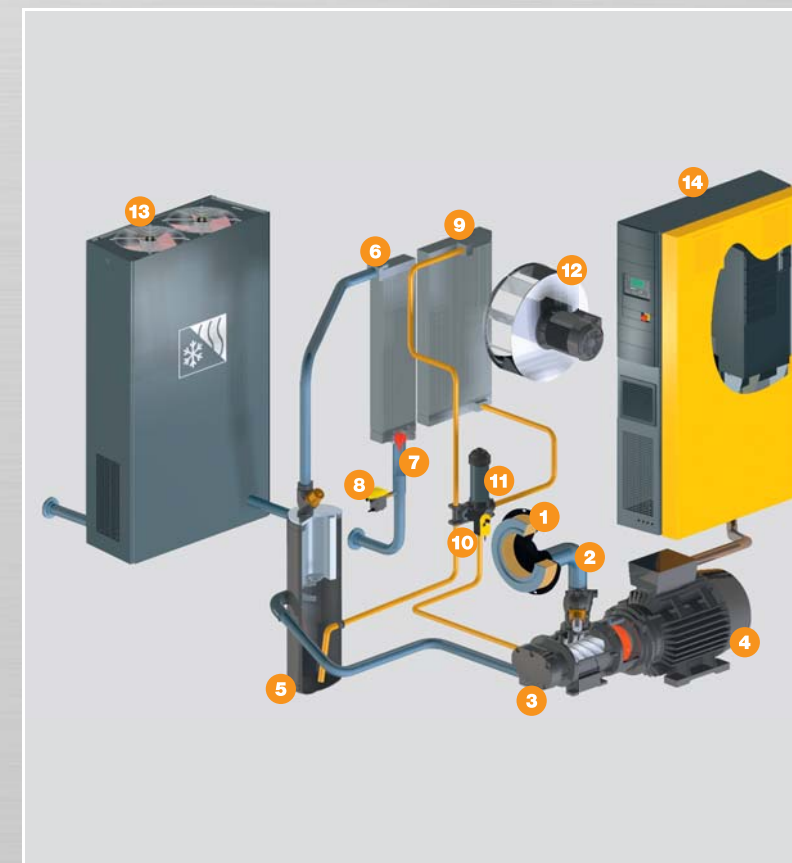

T SFC version

- 1 Intake filter
- 2 Inlet valve
- 3 Airend
- 4 Drive motor
- 5 Fluid separator tank
- 6 Compressed air aftercooler
- 7 KAESER centrifugal separator
- 8 Condensate drain (ECO-DRAIN)
- 9 Fluid cooler
- 10 Electrical temperature valve
- 11 Fluid filter
- 12 Radial fan
- 13 Integrated refrigeration dryer
- 14 Switching cabinet with integrated SFC frequency converter

Technical Specifications

Standard version

Model	Working pressure bar	FAD *) Complete package at working pressure m³/min	Max. working pressure bar	Rated motor power kW	Dimensions W x D x H mm	Compressed air connection	Sound pressure level **) dB(A)	Weight kg
BSD 65	7.5	5.65	8.5	30	1590 x 1030 x 1700	G 1½	69	970
	10	4.52	12					
	13	3.76	15					
BSD 75	7.5	7.00	8.5	37	1590 x 1030 x 1700	G 1½	70	985
	10	5.60	12					
	13	4.43	15					
BSD 83	7.5	8.16	8.5	45	1590 x 1030 x 1700	G 1½	71	1060
	10	6.85	12					
	13	5.47	15					



T - Version with integrated refrigeration dryer (R 134a refrigerant)

Model	Working pressure bar	FAD *) Complete package at working pressure m³/min	Max. working pressure bar	Rated motor power kW	Refrigeration dryer power consumption **) kW	Dimensions W x D x H mm	Compressed air connection	Sound pressure level **) dB(A)	Weight kg
BSD 65 T	7.5	5.65	8.5	30	0.8	1990 x 1030 x 1700	G 1½	69	1100
	10	4.52	12						
	13	3.76	15						
BSD 75 T	7.5	7.00	8.5	37	0.8	1990 x 1030 x 1700	G 1½	70	1115
	10	5.60	12						
	13	4.43	15						
BSD 83 T	7.5	8.16	8.5	45	0.8	1990 x 1030 x 1700	G 1½	71	1190
	10	6.85	12						
	13	5.47	15						



SFC - Version with variable speed drive

Model	Working pressure bar	FAD *) Complete package at working pressure m³/min	Max. working pressure bar	Rated motor power kW	Dimensions W x D x H mm	Compressed air connection	Sound pressure level **) dB(A)	Weight kg
BSD 75 SFC	7.5	1.54 - 7.35	10	37	1665 x 1030 x 1700	G 1½	72	1070
	10	1.52 - 6.47	10					
	13	1.16 - 5.50	15					



T SFC - Version with variable speed drive and integrated refrigeration dryer

Model	Working pressure bar	FAD *) Complete package at working pressure m³/min	Max. working pressure bar	Rated motor power kW	Refrigeration dryer power consumption **) kW	Dimensions W x D x H mm	Compressed air connection	Sound pressure level **) dB(A)	Weight kg
BSD 75 T SFC	7.5	1.54 - 7.35	10	37	0.8	2065 x 1030 x 1700	G 1½	72	1200
	10	1.52 - 6.47	10						
	13	1.16 - 5.50	15						



*) FAD in accordance with ISO 1217:2009, Annex C: absolute inlet pressure 1 bar (a), cooling and air intake temperature 20 °C

**) Sound pressure level as per ISO 2151 and the basic standard ISO 9614-2, tolerance: ± 3 dB(A)

Choose the required grade of treatment according to your field of application:

Air treatment using a refrigeration dryer (pressure dew point +3°C)

Application examples: Selection of treatment classes to ISO 8573-1 (2010)

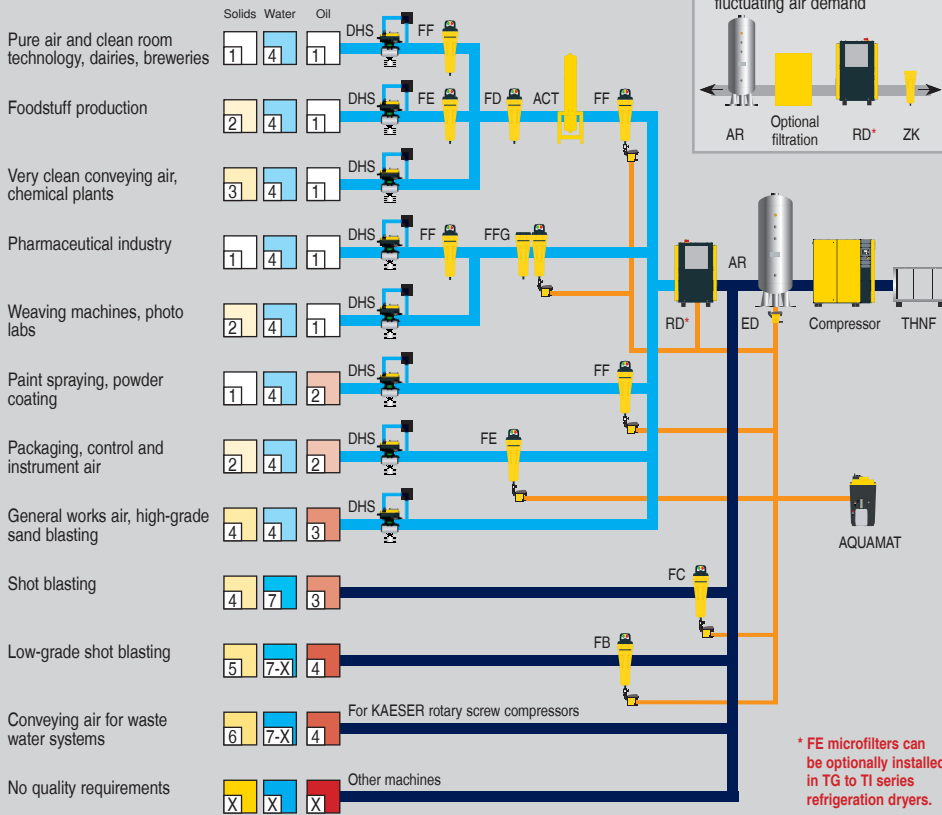

For non frost protected air systems: Compressed air treatment with a desiccant dryer (down to -70 °C pressure dew point)

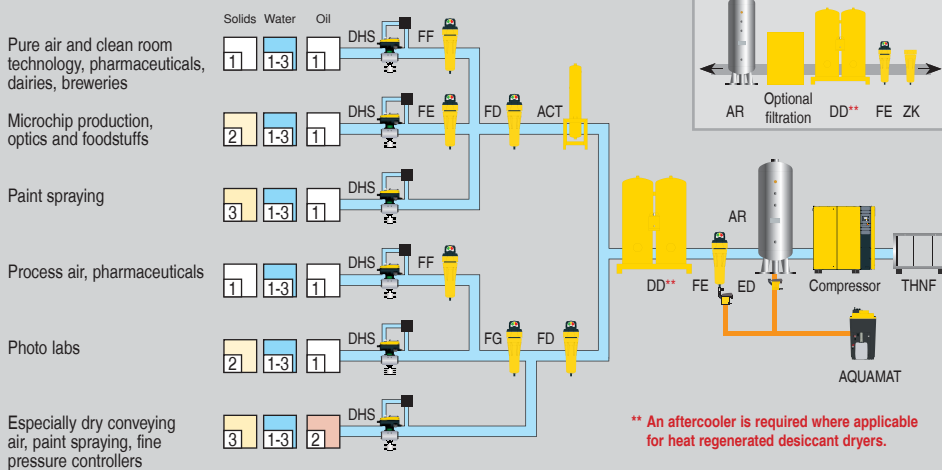

Explanation	
ACT	Activated carbon adsorber
AQUAMAT	AQUAMAT
DD	Desiccant dryer
DHS	Air-main charging system
AR	Air receiver
ED	ECO DRAIN
FB / FC	Pre-filter
FD	Particulate filter
FE / FF	Microfilter
FFG	Activated carbon and microfilter combination
FG	Activated carbon filter
RD	Refrigeration dryer
THNF	Bag filter
ZK	Centrifugal separator

Compressed air quality classes to ISO 8573-1(2010):

Solid particles / dust			
Class	max. particle count per m ³ of a particle size with d [µm]*		
	0.1 ≤ d ≤ 0.5	0.5 ≤ d ≤ 1.0	1.0 ≤ d ≤ 5.0
0	e.g. Consult KAESER regarding pure air and cleanroom technology		
1	≤ 20,000	≤ 400	≤ 10
2	≤ 400,000	≤ 6,000	≤ 100
3	Not defined	≤ 90,000	≤ 1,000
4	Not defined	Not defined	≤ 10,000
5	Not defined	Not defined	≤ 100,000
Particle concentration C _p in mg/m ³ *			
6	0 < C _p ≤ 5		
7	5 < C _p ≤ 10		
X	C _p > 10		

Water	
Class	Pressure dew point, in °C
0	e.g. Consult KAESER regarding pure air and cleanroom technology
1	≤ -70 °C
2	≤ -40 °C
3	≤ -20 °C
4	≤ +3 °C
5	≤ +7 °C
6	≤ +10 °C
Concentration of liquid water C _w in g/m ³ *	
7	C _w ≤ 0.5
8	0.5 < C _w ≤ 5
9	5 < C _w ≤ 10
X	C _w > 10

Oil	
Class	Total oil concentration (fluid, aerosol + gaseous) [mg/m ³]*
0	e.g. Consult KAESER regarding pure air and cleanroom technology
1	≤ 0.01
2	≤ 0.1
3	≤ 1.0
4	≤ 5.0
X	> 5.0

*) At reference conditions 20°C, 1 bar(a), 0% humidity



KAESER COMPRESSORS Australia Pty. Ltd.

Locked Bag 1406 – Dandenong South – Vic. 3164
45 Zenith Road – Dandenong – Vic. 3175

Phone: +61 3 9791 5999 – Fax: +61 3 9791 5733 – E-mail: info.australia@kaeser.com – www.kaeser.com